

Jacketed Products



FLEXTROL

- Weld-on Valve Jacketing
- Bolt-on Jacketing
- Jacketed Pipe and Fittings
- Jacketed Metal Hose
- Jump-over Hoses

Note: all photographs and drawings in this catalog are for illustration purposes only and should not be considered a standard jacket for all equipment.

Flextrol Corporation | 192 Browns Hill Rd. | Locust, NC (USA) 28097
Toll Free: 800-424-0212 | Tel: 704-888-1120 | Fax: 704-888-1123
www.flextrol.com | E-mail: info@flextrol.com

Flextrol Corporation was founded in March of 1982. We are a high quality manufacturer of jacketing for pipe, pipe fittings, valves, and other process equipment. Flextrol is recognized for:

- Quality Workmanship
- Technical Expertise
- Reliable Deliveries
- Competitive Pricing

Our goal is to provide the best product available on the market today. To achieve this goal, Flextrol has combined one of the most comprehensive Quality Assurance Programs in the industry with manufacturing performed by certified welders, in addition, we maintain product liability insurance for your protection.

Flextrol's staff are experts in the business. We know jacketing and can help you every stop of the way, whether quoting a price or assisting in design. We are also prepared to meet your emergency shutdown requirements and have technicians on call 24 hours a day. Our quick response to application problems gives us the competitive edge and gives you the service you deserve and expect.

As your single source supplier for complete jacketed systems, Flextrol Corporation ensures fully compatible systems at competitive prices. We are also your source for metal/Teflon* hose assemblies and metal, rubber, and Teflon* expansion joints.

Call us for product information, expert assistance, or emergency service. Flextrol Corporation is in business to serve you with quality products and on time deliveries.

Best regards,
FLEXTROL CORPORATION



R. B. Patterson
President

*Teflon is a registered trademark of DuPont

Weld-on Valve Jacketing

Flextrol's Weld-on Valve Jackets are produced in full coverage or partial coverage designs. The weld-on design places the heating media in direct contact with the valve body, thereby ensuring excellent and reliable heat transfer to the valve body. The valve bonnet may also be jacketed.

Our standard rating is 150 psig at 365 °F. Other pressure and temperature ratings are available. The jacket can be fabricated of carbon steel, stainless steel, or other alloys. All finished jacketed valves are pressure tested on both the heating side and the process side before shipment. Flextrol specializes in calibrating control valve positioners, both pneumatic and electro-pneumatic, prior to shipment.

Normally, we provide 1/2" female NPT ports on 1" through 2 1/2" valves, 3/4" ports on 3" through 6" valves, and 1" ports on 8" and larger valves.

Full Coverage with Oversized Flanges

This design allows heating media to contact both the valve body and that portion of the flange within the bolt circle. Standards for this design require that the flanges be oversized by one full size over the valve size. The finished face-to-face dimension will conform to ANSI standards for the oversized flange.

The cover and the adjacent photograph show typical jacketed valves with full coverage, oversized flanges. The drawing shows a cross section of a typical jacketed ball valve design.

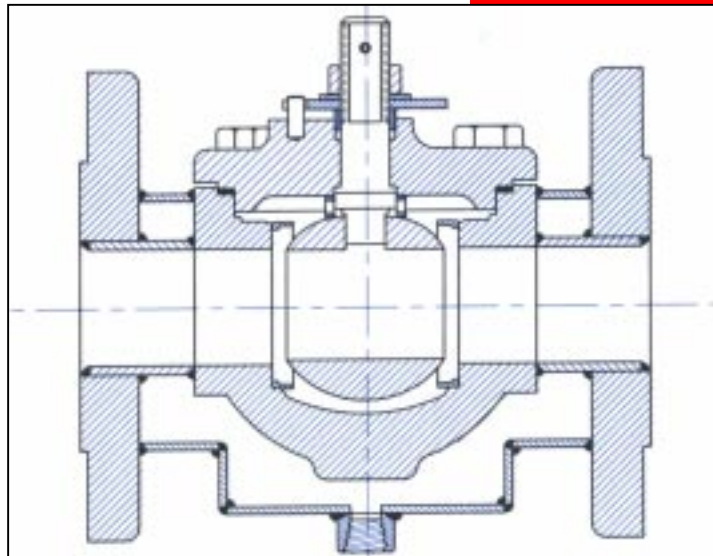
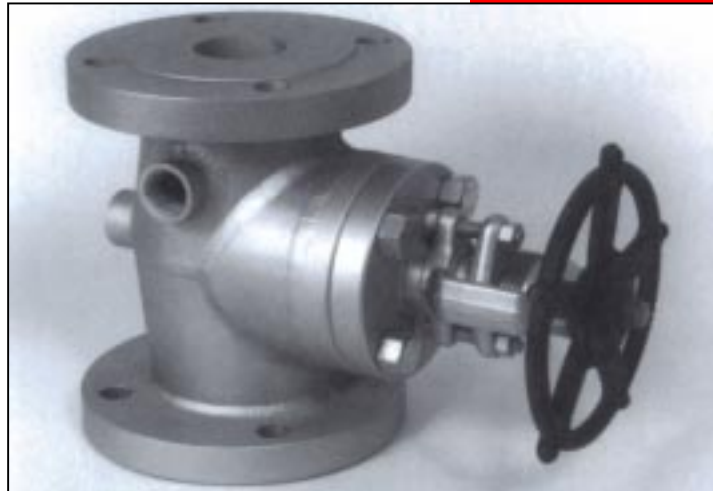

Full Coverage with Standard Flanges

Standard flanged valves can be fully jacketed. This compact design is accomplished by installing blind, tapped inserts in the flange bolt holes, with the jacket welded to the periphery of the flange. Flextrol's unique design will allow the heating media to come into contact with the valve body and flanges.

The photograph shows a full coverage, standard flange ball valve. The drawing shows a typical ball valve design.

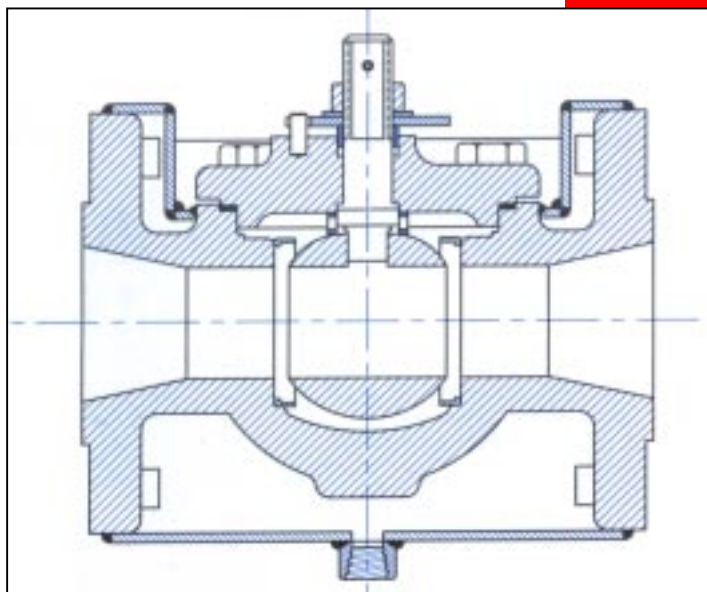

Partial Coverage with Standard Flanges

When standard flanges are required and full coverage is not necessary, partial coverage is appropriate. The reliability and excellent heat transfer characteristics of the weld-on jacket are retained, but flange heating is indirect.

In the partial coverage design, only the mid-section of the valve body is enclosed in the jacket, thereby leaving clearance for flange bolt-up.

Flextrol Partial Jackets can be added to ball valves, globe valves, plug valves, gate valves, butterfly valves, check valves, sampling valves and other process equipment.

The photograph illustrates a partial coverage, standard flange gate valve. The drawing is the same jacket concept applied to a ball valve.

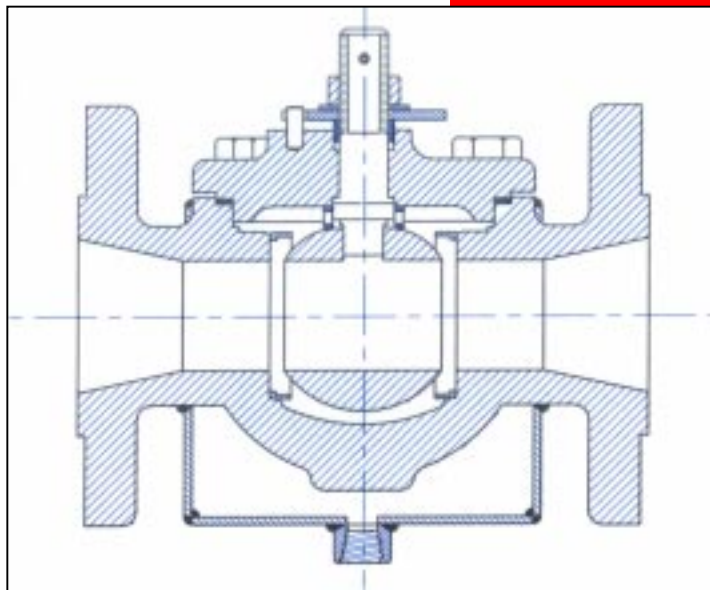
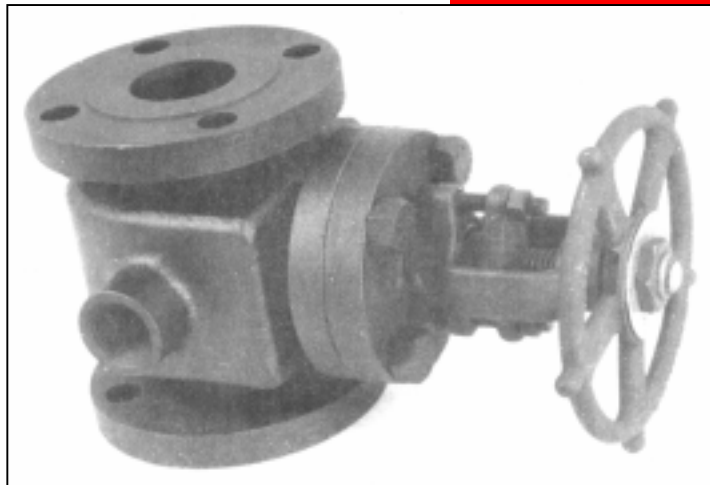

Bolt-on Valve Jacketing

The photograph shows a duplex strainer with a bolt-on jacket.



Flextrol Bolt-on Jackets can be provided for most process piping components including all types of pipe fittings, valves, pumps, and strainers. Our jackets are custom fabricated to correctly fit the component being jacketed. Carbon steel is our standard jacket material, but stainless steel and other alloys are available. Our fabricated Bolt-on Jacket has a large heating chamber which provides efficient temperature control over the total surface of the component's body and flanges. Heat transfer compound is applied between the component and the jacket to ensure good heat transfer.

This is accomplished without the expense of premium materials, and without concern for controlling welding stresses within the structure of the component being jacketed. In addition, there is no risk of cross contamination with the bolt-on design.

Maintenance, repair, or modification is particularly easy since the jacket can be removed without entering the process itself. Also, replacement jackets can be fabricated at Flextrol without removing and returning the installed piping component.

Bolt-on Valve Jacketing

Flextrol's standard design is rated at 150 psig, 650°F. Standard jackets are carbon steel construction with female NPT ports. Other ratings and port configurations are available. Our experienced personnel design, manufacture, and test the fabricated jacket.

Bolt-on jacketing is available for globe, gate, ball, check, and relief valves. It is suitable for either manual or actuated valves. Flextrol can also apply the bolt-on design concept to pumps and other process equipment.

Pictured to the right is a bolt-on jacket applied to a gate valve.

The drawing below shows a typical jacketed ball valve design.

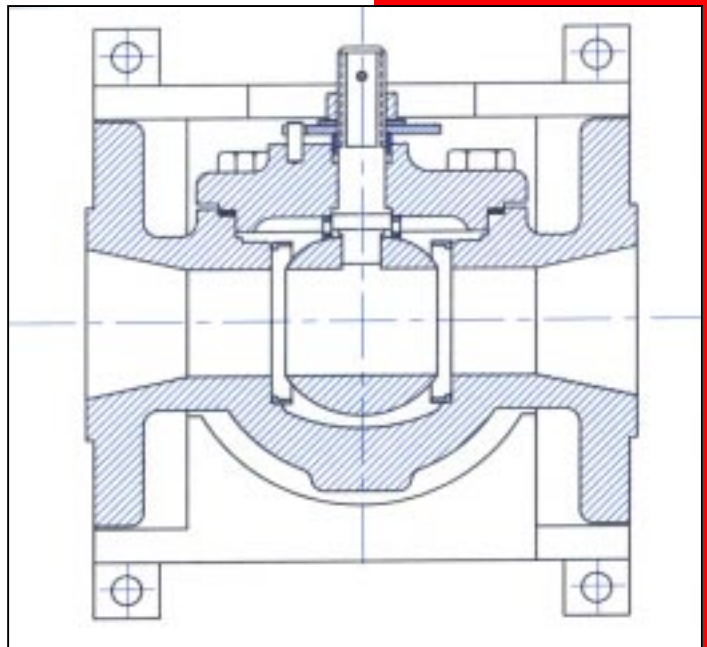

Jacketed Pipe

Flextrol's standard jacketed pipe consists of a full length jacket that is welded to the back of oversized flanges. The core (product) pipe is welded to the bore of the flanges. This design, shown in the pipe photograph (right) and in the upper drawing, provides ideal temperature uniformity.



Partial coverage jacketed pipe made with flanges that match the product line size is also available. A partial jacket is welded to the core pipe near the back of the flange (see lower drawing and left side of photograph). Jacketed pipe can also be produced using lap joint, weld-neck, and insert type flanges.

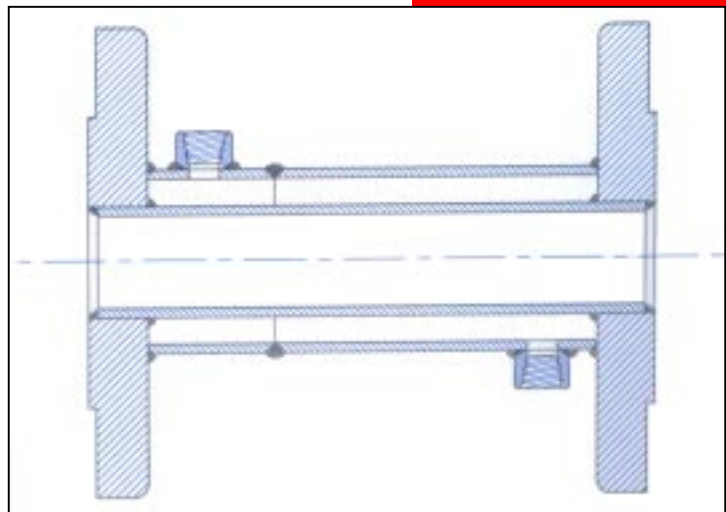

Jacket ports are normally 3000 psig female NPT half couplings arranged 180° apart: 1/2" ports for up to 2 1/2" pipe, 3/4" ports for 3" through 6" pipe, and 1" ports for larger pipe sizes. Consult with Flextrol for specific dimensions.

Custom pipe can be provided combining elbows, tees, etc. per the customer's drawing.

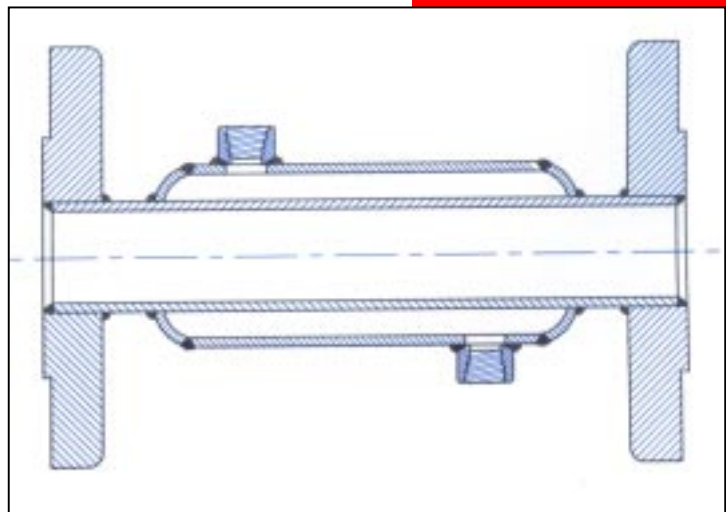

Jacketed Pipe Fittings

Flextrol's jacketed elbows, tees, crosses and reducers are fabricated from the highest quality materials in various combinations of carbon and stainless steel or other alloys. While 150 and 300 psig flanges are standard, other designs and pressure ratings are available.

The weld-on design, utilizing oversized flanges is Flextrol's standard for jacketed pipe fittings. The drawing and photograph show a standard weld-on jacket for a tee.

The advantages and features of Flextrol's jacketed pipe also apply to jacketed pipe fittings.

We also provide bolt-on jackets for pipe fittings. Contact us for dimensions and/or drawings.

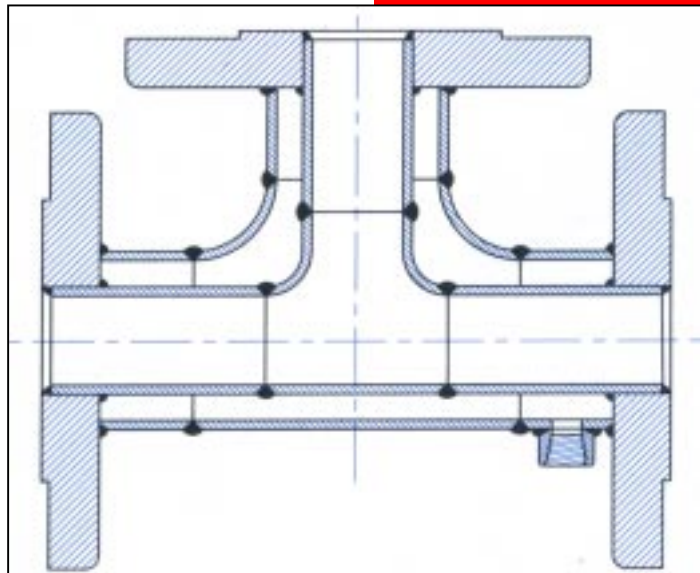

Jacketed Hose

Jacketed hose consists of flexible metal hose for both the core and outer jacket. This allows flexibility for the following applications:

- Heated processes.
- Rail car and tank truck loading/unloading.
- Flexible connections to vibrating equipment.
- To relieve pump housing stresses.
- Hazardous material piping system using an alarmed vacuum jacket.
- Vacuum jacketed hoses for heat insulation.

Standard core constructions are available in ID sizes from 1/4" to 24" in T-321 and T-316L stainless steel with outer jackets available up to 30" ID.

Standard jacketing ports are 3000 lb. female NPT pipe couplings arranged 180° apart. Other port configurations, pressure ratings, end fittings and materials are available.

Photos show flanged ends (top image) and threaded ends (bottom image).

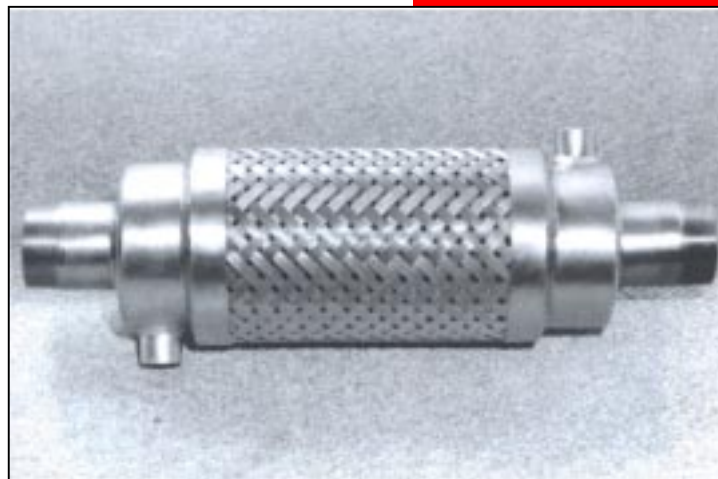
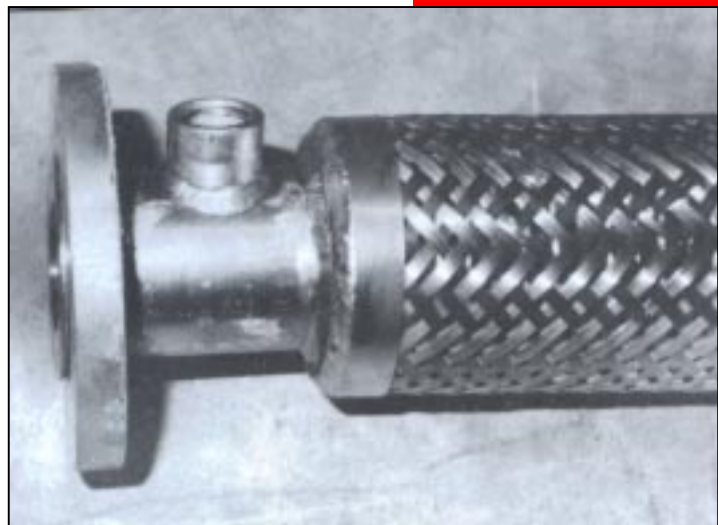

Jumper Hoses

Flextrol also provides jumper hoses to interconnect the numerous jackets in a jacketed piping system. These hoses are available in standard diameters of 1/2", 3/4" and 1" male NPT pipe. Jumper hoses are made from stainless steel flexible hose, and can be insulated with fiberglass/silicone covers. Standard lengths include 24", 28" and 30" with other lengths available.

The first page of this PDF brochure shows how jumper hoses interconnect jacket sections in series.

The top photo on this page shows a typical valve jacket to pipe jacket connection.

The bottom photo shows Flextrol's standard design with a hose containing a rigid fitting on one end and a swivel fitting on the other.

Note: all photographs and drawings in this catalog are for illustration purposes only and should not be considered a standard jacket for all equipment.

